

*IDE 4000 Flash Disk*

*1.8" and 2.5"*

*Product Specification and User Manual*

January 2005  
34-PS-0304-00 Rev. 2.1

---

## DOCUMENT CONTROL INFORMATION

DCO No.:

	<b>Title</b>	<b>Name</b>	<b>Date</b>
<b>Issued by:</b>	VP Marketing, Embedded Division	Ofer Tsur	January 5, 2005

## REVISION HISTORY

<b>Revision</b>	<b>Date</b>	<b>Description</b>	<b>Reference</b>
2.0	June 7, 2004	Added information for new 1.8" form factor	--
2.1	January 2, 2004	Updated available capacity information Updated reliability information Updated supported temperature ranges Update CHS settings information	Section 1.2.8 Section 1.2.9 Sections 1.3.1, 9 Section 1.2.8

## TABLE OF CONTENTS

<b>1. Specifications.....</b>	<b>5</b>
1.1. Critical Item Definition .....	5
1.2. Characteristics.....	5
1.2.1. Interface Definition.....	5
1.2.2. IDE Transfer Modes.....	5
1.2.3. Performance .....	5
1.2.4. Access Time .....	6
1.2.5. Seek Time.....	6
1.2.6. Input Voltage.....	6
1.2.7. Current Consumption.....	6
1.2.8. Memory Capacity.....	7
1.2.9. Endurance.....	8
1.2.10. Mean Time Between Failures (MTBF).....	8
1.2.11. Physical Characteristics.....	8
1.3. Environmental Conditions .....	11
1.3.1. Temperature .....	11
1.3.2. Altitude .....	12
1.3.3. Relative Humidity.....	12
1.3.4. Shock .....	12
1.3.5. Vibration.....	12
1.3.6. Storage Life and Data Retention .....	12
<b>2. Drive Configuration.....</b>	<b>13</b>
<b>3. Interface Connectors .....</b>	<b>14</b>
<b>4. Supported IDE Commands.....</b>	<b>15</b>
<b>5. CE and FCC Compatibility.....</b>	<b>16</b>
<b>6. Label Information .....</b>	<b>17</b>
<b>7. Using the IDE 4000 Flash Disk.....</b>	<b>18</b>
7.1. Unpacking the Drive .....	18
7.2. Handling Instructions.....	18
7.3. Installing the Drive in a PC .....	18
7.4. Using the IDE 4000 in an MS-DOS-Based Platform .....	19
7.5. Troubleshooting .....	19
7.6. How to Get Help.....	20

<b>8. Warranty.....</b>	<b>21</b>
<b>9. Ordering Information .....</b>	<b>22</b>
<b>How to Contact Us .....</b>	<b>23</b>

## 1. SPECIFICATIONS

### 1.1. Critical Item Definition

The dimensions of the IDE 4000 flash disk enable mounting in a standard 2.5” or 1.8” disk drive bay, as described in Section 1.2.11.

Note: The information written in this document refers to both IDE 4000 2.5” and 1.8” unless otherwise stated.

### 1.2. Characteristics

#### 1.2.1. Interface Definition

The IDE 4000 supports the commands listed in Section 4, in compliance with ATA4 standards.

#### 1.2.2. IDE Transfer Modes

The IDE 4000 supports the following transfer modes:

- PIO modes 0 through 4
- DMA modes 0 through 2

#### 1.2.3. Performance

The IDE 4000 complies with the performance requirements described in Table 1.

*Table 1: IDE 4000 Transfer Rates*

Operation	Burst Rate (MB/sec)	Sustained Rate (MB/sec)
Read	16.6	3.8
Write	16.6	3.4

Performance was measured on a system with the following configuration:

- Computer with ASUS P4T533-C motherboard and Intel 2.4 GHz processor
- Windows XP Professional operating system
- IDE transfer mode: Multiword DMA 2
- IDE 4000 disk capacity: 4GB

The HDTACH v2.61 benchmark utility was used to measure IDE 4000 performance. See Figure 1 for measurement results.

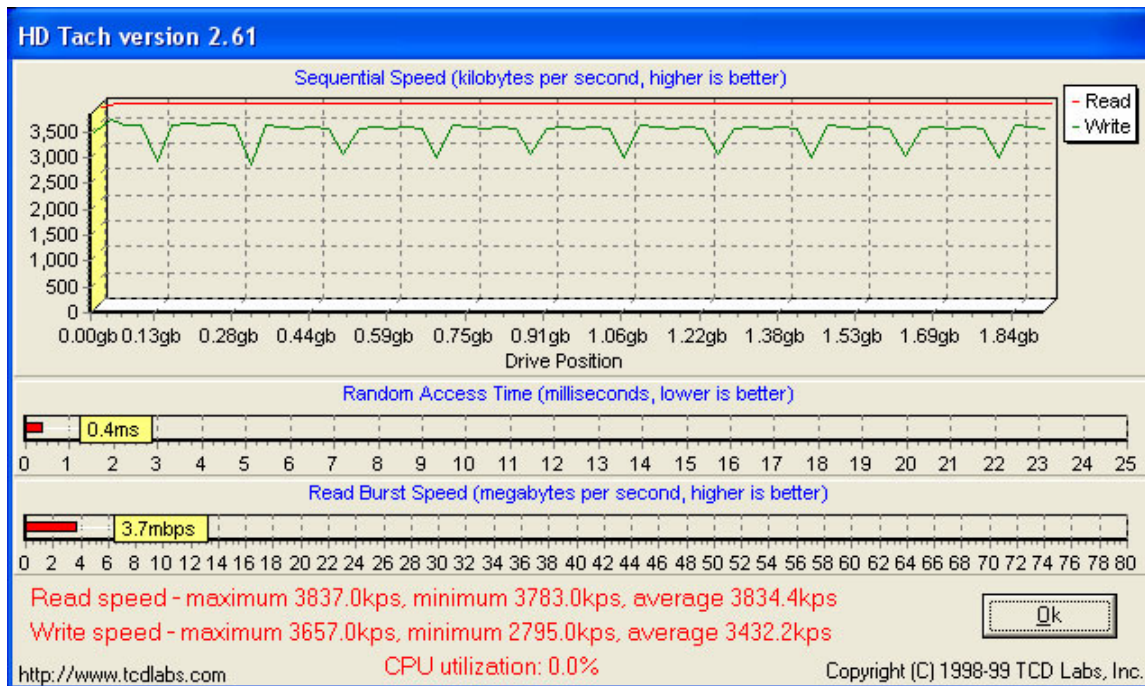

Figure 1: IDE 4000 Performance Results

#### 1.2.4. Access Time

Standby to active (typical.): 0.1 msec

#### 1.2.5. Seek Time

The IDE 4000 has no seek time, as it has no moving parts.

#### 1.2.6. Input Voltage

The IDE 4000 input voltage is 3.3VDC to 5.0VDC.

#### 1.2.7. Current Consumption

The current consumption at an input voltage of +5 VDC is described in Table 2.

Table 2: IDE 4000 Input Current Consumption with +5 VDC Input Voltage

Function/Mode	Current (max) mA DC
Read	23.0
Write	23.0
Idle/Sleep	5.0

The current consumption at an input voltage of +3.3 VDC is described in Table 3.

*Table 3: IDE 4000 Input Current Consumption with +3.3VDC Input Voltage*

Function/Mode	Current (max) mA DC
Read	16.0
Write	16.0
Idle/Sleep	< 1

### 1.2.8. Memory Capacity

As of software version 1.09, the changes listed in Table 4 apply to the CHS (Cylinder, Heads, Sectors) settings for the IDE 4000, capacities 128MB to 512MB (there are no changes for other capacities).

*Table 4: CHS Settings for Low-Capacity IDE 4000*

Capacity (MB)	Cylinder		Heads		Sectors	
	V1.08	V1.09	V1.08	V1.09	V1.08	V1.09
128	993	500	8	16	32	32
256	998	1000	16	16	32	32
512	1015	1015	16	16	63	63

Table 5 describes the different densities of the IDE 4000 (unformatted, in MB).

*Table 5: IDE 4000 Flash Disk Capacities*

Disk Capacity (MB)	Disk Capacity (MB)
128	2048
256	2560
384	3072
512	3584
640	4096
768	5120
1024	6144
1280	7168
1536	8192
1792	

### 1.2.9. Endurance

The IDE 4000 provides 2,000,000 write/erase cycles and an unlimited number of read cycles. Performance is enhanced by the following features:

- **Wear-Leveling Algorithm:** This algorithm guarantees the use of all flash components at the same level of the write/erase cycle.
- **EDC/ECC (Error Detection Code/Error Correction):** The enhanced Reed-Solomon EDC/ECC extends disk endurance by detecting and then fixing flash blocks.

### 1.2.10. Mean Time Between Failures (MTBF)

Table 6 summarizes the MTBF prediction results for various IDE 4000 configurations. The analysis was performed using a RAM Commander™ failure rate prediction.

*Table 6: IDE 4000 MTBF*

Product	Condition	MTBF (Hours)	Failure Rate per Million Hours
IDE 4000 1GB	Telcordia SR-332, GB, 25°C	2,893,495	0.3456
IDE 4000 2GB	Telcordia SR-332, GB, 25°C	2,188,066	0.4570
IDE 4000 3GB	Telcordia SR-332, GB, 25°C	1,759,180	0.5684
IDE 4000 4 to 8GB	Telcordia SR-332, GB, 25°C	1,470,874	0.6799

A detailed MTBF report can be furnished upon request.

### 1.2.11. Physical Characteristics

#### 1.2.11.1 Weight

The weight of the IDE 4000 complies with the values defined in Table 7.

*Table 7: IDE 4000 Maximum Weight*

Memory Capacity (MB)	2.5" Unit Weight (g)	1.8" Unit Weight (g)
8192	90	30

#### 1.2.11.2 Dimensions

Table 8 describes the nominal dimensions of the IDE 4000. Refer to Figure 2 for detailed mounting configuration dimensions.

*Table 8: Nominal Dimensions*

Dimensions	IDE 4000 2.5"		IDE 4000 1.8"	
	Height	Width	Height	Width
Height	0.291 in	7.40 mm	0.339 in	8.6 mm
Width	2.750 in	69.85 mm	2.008 in	51.0 mm
Depth	3.945 in	100.20 mm	3.004 in	76.3 mm





### 1.2.11.3 Connector Interface

The pinout for the IDE 4000 interface connector is detailed in Table 9 and in Figure 4.

*Table 9: J1 Pin Assignment*

Pin Number	Signal Name	Pin Number	Signal Name
1	RESET-	2	GND
3	HD7	4	HD8
5	HD6	6	HD9
7	HD5	8	HD10
9	HD4	10	HD11
11	HD3	12	HD12
13	HD2	14	HD13
15	HD1	16	HD14
17	HD0	18	HD15
19	GND	20	KEY
21	N.C.	22	GND
23	HIOW-	24	GND
25	HIOR-	26	GND
27	IORDY	28	CSEL
29	N.C.	30	GND
31	INTRQ	32	IOCS16-
33	HA1	34	PDIAG-
35	HA0	36	HA2
37	CS0-	38	CS1-
39	DASP-	40	GND
41	VCC	42	VCC
43	GND	44	RSVD

*Table 10: J2 Pin Assignment*

Pin Number	Signal Name	Pin Number	Signal Name
47	Master/Slave	48	Master/Slave
49	Master/Slave	50	Master/Slave

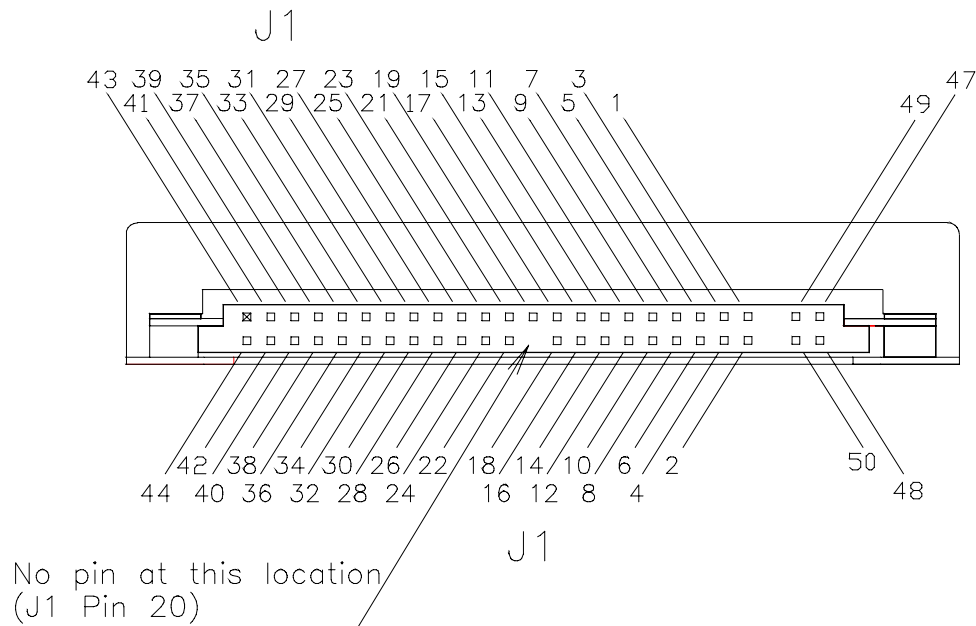

Figure 4: IDE 4000 Pin Configuration

## 1.3. Environmental Conditions

The IDE 4000 meets the performance requirements specified below, after exposure to non-operating environmental conditions, or during and after exposure to operating environmental conditions.

### 1.3.1. Temperature

#### 1.3.1.1 Operating

The IDE 4000 operates without degradation at a pressure of 1 atm over the following ambient temperature range:

- Commercial temperature version: 0°C to +70°C : for IDE 4000 2.5” and 1.8”
- Extended temperature version: -40°C to +85°C :for IDE 4000 2.5”

The maximum temperature change rate shall not exceed 5°C per minute.

#### 1.3.1.2 Non-Operating

The IDE 4000 commercial temperature version meets the performance requirements specified in this document after having been tested via exposure to a nominal ambient temperature of -55°C for not less than 3 days, and +95°C for a period of not less than 6 hours.

The maximum temperature change rate shall not exceed 5°C per minute.

### **1.3.1.3 Airflow Requirements**

General airflow guideline: 3-5 cu.feet/min.

### **1.3.2. Altitude**

The IDE 4000 sustains full operation at altitudes ranging from sea level to 80,000 feet above sea level. It is also capable of full operation during air transportation via non-pressurized flights at altitudes greater than 80,000 feet above sea level.

### **1.3.3. Relative Humidity**

The IDE 4000 withstands conditions of 8% to 95% non-condensing relative humidity (operation and non-operation).

### **1.3.4. Shock**

The IDE 4000 sustains full operation after being subjected to 1000 G shock testing in the vertical axis.

### **1.3.5. Vibration**

The IDE 4000 remains operational without degradation while being subjected to a 15 G vibration condition.

### **1.3.6. Storage Life and Data Retention**

The IDE 4000 can be placed in non-operational storage in shipping containers or crates for a period of up to 3 years without its capabilities being permanently affected. The IDE 4000 has a data retention span of over 10 years.

## 2. DRIVE CONFIGURATION

The IDE 4000 must be configured as shown in Figure 5 before being mounted in the system's drive bay.

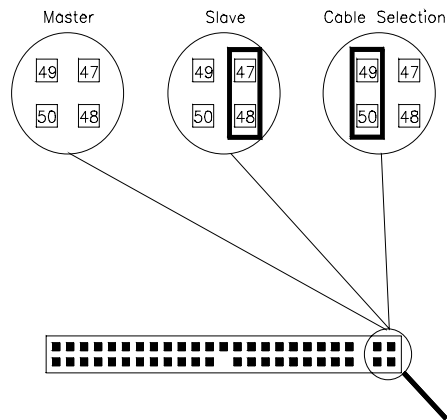

*Figure 5: IDE 4000 Disk Address Setting by Jumper*

### 3. INTERFACE CONNECTORS

The IDE 4000 has a 2-mm pitch interface connector located on the rear panel. It accesses the DC power source and the IDE bus through a non-shielded 44-pin flat cable. Figure 6 provides an example of a connector that can be used to interface with this connector, but any compatible connectors may be used.

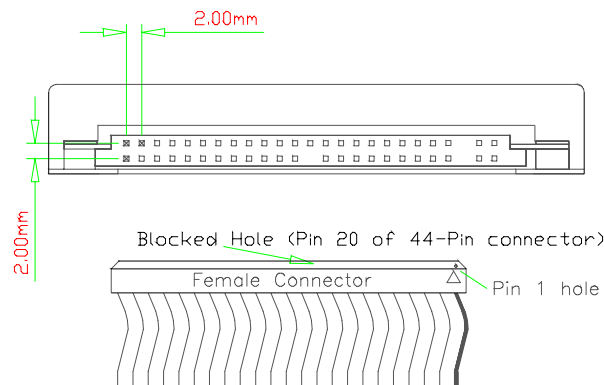

*Figure 6: IDE 4000 Interface Connector*

In order to prevent damage to the disk by connecting the cable with a 180° rotation, ensure that the special plastic key at pin 20 mating connector is blocked, as shown in Figure 6. This key should be ordered from the connector manufacturer.

#### **IDE Cable**

The cable length should not exceed 18 inches.

## 4. SUPPORTED IDE COMMANDS

The IDE 4000 supports the commands listed in Table 11.

*Table 11: IDE Commands*

Command Name	Command Code
CHECK POWER MODE	98h E5h
EXECUTE DEVICE DIAGNOSTIC	90h
FORMAT TRACK	50h
IDENTIFY DEVICE	Ech
IDLE	97h E3h
IDLE IMMEDIATE	95h E1h
INITIALIZE DEVICE PARAMETERS	91h
READ BUFFER	E4h
READ DMA (with retry)	C8h
READ DMA (without retry)	C9h
READ MULTIPLE	C4h
READ SECTOR(S) (with retry)	20h
READ SECTOR(S) (without retry)	21h
READ LONG	22h 23h
READ VERIFY SECTOR(S) (with retry)	40h
READ VERIFY SECTOR(S) (without retry)	41h
RECALIBRATE	10h
SEEK	70h
SET FEATURES	Efh
SET MULTIPLE MODE	C6h
SLEEP	99h E6h
STANDBY	96h E2h
STANDBY IMMEDIATE	94h E0h
WRITE BUFFER	E8h
WRITE DMA (with retry)	CAh
WRITE DMA (without retry)	CBh
WRITE MULTIPLE	C5h
WRITE SECTOR(S) (with retry)	30h
WRITE SECTOR(S) (without retry)	31h
WRITE LONG	32h 33h

## **5. CE AND FCC COMPATIBILITY**

The IDE 4000 complies with the following CE requirements and FCC standards:

- FCC Part 15 Class B
- EN 55022 Class B, CISPR 22 Class B (MIC)
- V-3/2001.04 Class B (Japan), AS/NZS 3548 Class B (Australia/NZ)
- BSMI CNS 13438 Class B (Taiwan)
- CAN/CSA-CISPR 22-96 Class B (Canada) CFR 47 FCC Class B
- EN 55024, EN 61000 (EMC)



## 6. LABEL INFORMATION

The outside label contains the following information:



*Figure 7: Outside Label*

1. CE and FCC logos
2. Product name
3. Unformatted capacity value
4. M-Systems logo
5. Ordering information
6. Serial number, including date code
7. Part number
8. Declaration
9. ESD warning logo and statement

## 7. USING THE IDE 4000 FLASH DISK

The IDE 4000 is shipped with the following components:

- Warranty certificate indicating M-Systems' 36-month warranty
- Four screws and one jumper, in kit no. 48-PK-001-00

If any of these items is missing, please contact your dealer.

### 7.1. Unpacking the Drive

Before unpacking or handling a drive, take all proper electrostatic discharge (ESD) precautions, including personnel and equipment grounding.

Before you begin installing the IDE 4000 in your system, perform a visual inspection and follow the recommendations below:

- If the shipping container appears to be damaged or water-stained, notify your dealer.
- Remove the disk from its shipping enclosure and inspect it for any damage that may have occurred during shipment. If any damage is observed, notify your dealer.
- Record the disk serial number and shipment date.
- Retain the original shipping enclosure and all packing material for re-shipment.

### 7.2. Handling Instructions

You can prolong the life of your IDE 4000, increase its reliability, and prevent unnecessary damage by following the instructions listed below. Failure to follow any of these instructions may void your warranty.

- Always take all proper electrostatic discharge (ESD) precautions, including personnel and equipment grounding.
- Always operate the flash disk within the environmental specifications.
- Always use a grounded wrist strap when handling the flash disk.
- Never switch DC power to the drive by plugging an electrically live source cable into the drive's power connector.
- Pay attention to the cable polarity whenever connecting the drive to the cable.

### 7.3. Installing the Drive in a PC

**To install the IDE 4000:**

1. Power off the PC and remove the cover.
2. Configure the IDE 4000 jumper settings according to the information provided in Section 2.

- 
3. Connect a 44-pin ribbon cable between the IDE 4000 and the adapter. Make sure to orient the cable so that pin 1 of the IDE 4000 is connected to pin 1 of the host adapter.
  4. Mount the IDE 4000 in a free drive bay.
  5. Close the PC cover and power on the PC.

The host BIOS sign-on message appears and displays a key sequence to enter the BIOS setup. Set up the BIOS to recognize the IDE 4000.

## 7.4. Using the IDE 4000 in an MS-DOS-Based Platform

After installing the IDE 4000, it must be installed as a disk drive under DOS. Run the DOS commands listed below and follow the instructions displayed for each command. For more information regarding DOS commands, refer to your DOS manual.

- Run the DOS FDISK program to partition the IDE 4000.
- Run the DOS FORMAT command to high-level format the IDE 4000.
- If you want the IDE 4000 to be a bootable drive, run the DOS SYS command and change the partition to active.

## 7.5. Troubleshooting

The problems that arise in most installations can be summarized below:

Cables:

- Homemade, short, flat ribbon cables with bad contacts or cheap cables
- Mixing round cables with flat cables.

Cable Length:

- The cable exceeds the length specified in the standard
- Cables are too long to support the transfer rate.

Device Address Conflict:

- A new device was added with an IDE setting identical to an existing device on the bus.
- Connection problems.
- A cable was connecting with reverse polarity.

## 7.6. How to Get Help

If you need technical assistance with the installation and configuration of your IDE 4000, please contact your customer support representative and have the following information available:

- Product and serial number of your IDE 4000
- Description of your computer hardware (manufacturer, model, attached devices, etc.)
- Description of your IDE host adapter and associated drivers
- Description of your software (operating system, version, application software, etc.)
- A complete description of the problem
- The exact wording of any error messages

Before contacting M-Systems directly, first contact your dealer (if you did not purchase you IDE 4000 directly from M-Systems). If your dealer cannot provide the help you need, you can obtain technical support directly from M-Systems at one of the numbers in the list of offices on the last page of this manual, or from the M-Systems website [www.m-systems.com](http://www.m-systems.com).

## **8. WARRANTY**

The warranty period of the IDE 4000 is 36 months (3 years). For details, please refer to the warranty certificate, which is included with the IDE 4000.

## 9. ORDERING INFORMATION

Ordering information for the IDE 4000 2.5": IDE-4K-25-CCCC-T

Ordering information for the IDE 4000 1.8": IDE-4K-18-CCCC-T

Where:

CCCC: Capacity (MB) 128, 256, 384, 512, 640, 768, 1024, 1280, 1536, 1792, 2048,  
2560, 3072, 3584, 4096, 5120, 6144, 7168, 8192

T: Temperature Range Blank Commercial: 0°C to +70°C (for 2.5" and 1.8")  
X Extended: -40°C to +85°C (for 2.5" only)

Note: the IDE 4000 in a 1.8" casing is available only in commercial temperature range.

---

## HOW TO CONTACT US

### USA

M-Systems Inc.  
555 North Mathilda Avenue, Suite 220  
Sunnyvale, CA 94085  
Phone: +1-408-470-4440  
Fax: +1-408-470-4470

### Japan

M-Systems Japan Inc.  
Asahi Seimei Gotanda Bldg., 3F  
5-25-16 Higashi-Gotanda  
Shinagawa-ku Tokyo, 141-0022  
Phone: +81-3-5423-8101  
Fax: +81-3-5423-8102

### Taiwan

M-Systems Asia Ltd.  
14 F, No. 6, Sec. 3  
Minquan East Road  
Taipei, Taiwan, 104  
Tel: +886-2-2515-2522  
Fax: +886-2-2515-2295

### China

M-Systems China Ltd.  
Room 121-122  
Bldg. 2, International Commerce & Exhibition Ctr.  
Hong Hua Rd.  
Futian Free Trade Zone  
Shenzhen, China  
Phone: +86-755-8348-5218  
Fax: +86-755-8348-5418

### Europe

M-Systems Ltd.  
7 Atir Yeda St.  
Kfar Saba 44425, Israel  
Tel: +972-9-764-5000  
Fax: +972-3-548-8666

### Internet

[www.m-systems.com](http://www.m-systems.com)

### General Information

[info@m-systems.com](mailto:info@m-systems.com)

### Sales and Technical Information

[techsupport@m-systems.com](mailto:techsupport@m-systems.com)

This document is for information use only and is subject to change without prior notice. M-Systems Flash Disk Pioneers Ltd. assumes no responsibility for any errors that may appear in this document. No part of this document may be reproduced, transmitted, transcribed, stored in a retrievable manner or translated into any language or computer language, in any form or by any means, electronic, mechanical, magnetic, optical, chemical, manual or otherwise, without prior written consent of M-Systems.

M-Systems products are not warranted to operate without failure. Accordingly, in any use of the Product in life support systems or other applications where failure could cause injury or loss of life, the Product should only be incorporated in systems designed with appropriate and sufficient redundancy or backup features.

Contact your local M-Systems sales office or distributor, or visit our website at [www.m-systems.com](http://www.m-systems.com) to obtain the latest specifications before placing your order.

© 2005 M-Systems Flash Disk Pioneers Ltd. All rights reserved.

M-Systems, DiskOnChip, DiskOnChip Millennium, DiskOnKey, DiskOnKey MyKey, FFD, Fly-By, iDiskOnChip, iDOC, mDiskOnChip, mDOC, Mobile DiskOnChip, Smart DiskOnKey, SmartCaps, SuperMAP, TrueFFS, uDiskOnChip, uDOC, and Xkey are trademarks or registered trademarks of M-Systems Flash Disk Pioneers, Ltd. Other product names or service marks mentioned herein may be trademarks or registered trademarks of their respective owners and are hereby acknowledged. All specifications are subject to change without prior notice.